

ALTA RESISTENCIA / HIGH TENSILE

CALIDAD > 8 / CLASS > 8

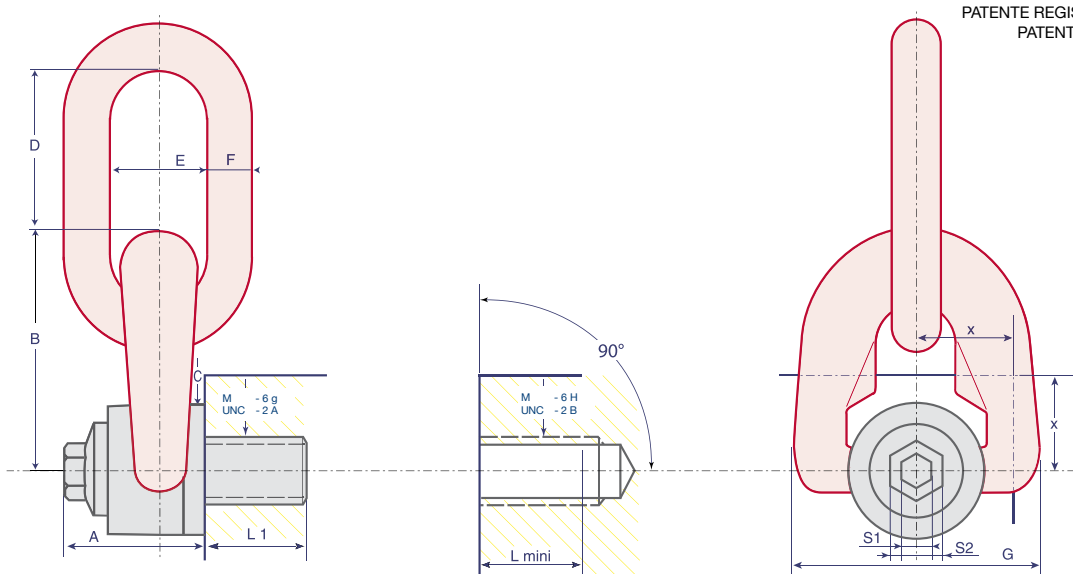

PATENTE REGISTRADA
PATENTS FILED



1,000 LBS = 0,4536 T

Referencia Reference	CMU WLL	Coef. Seguridad Safety Factor	Diámetro Diameter	Standard L1	N.m. Foot. LBS	X	S1	S2	A	B	C	D	E	F	G	Peso Weight
CTSR-8	0,3 T	5	M8 (x1,25)	14	6	18	8	16	33	56	30	41	25	10	58	0,4 Kg
CTSR-10	0,6 T	5	M10 (x1,50)	17	10	18	8	16	33	56	30	41	25	10	58	0,4 Kg
CTSR-12	1 T	5	M12 (x1,75)	21	15	18	8	16	33	56	30	41	25	10	58	0,4 Kg
CTSR-14*	1,3 T	5	M14 (x2)	23	30	24	8	20	45	76	45	56	37	14	79	1,1 Kg
CTSR-16	1,6 T	5	M16 (x2)	27	50	24	8	20	45	76	45	56	37	14	79	1,2 Kg
CTSR-18*	2 T	5	M18 (x2,5)	27	70	28	8	20	45	76	45	56	37	14	79	1,2 Kg
CTSR-20	2,5 T	5	M20 (x2,5)	30	100	28	8	20	45	81	45	56	37	14	79	1,2 Kg
CTSR-22*	3 T	5	M22 (x2,5)	33	120	45	14	24	62	105	60	80	45	20	106	2,8 Kg
CTSR-24	4 T	5	M24 (x3)	36	160	45	14	24	62	105	60	80	45	20	106	2,9 Kg
CTSR-27*	5 T	5	M27 (x3)	36	160	45	14	24	62	105	60	80	45	20	106	2,9 Kg
CTSR-30	6,3 T	5	M30 (x3,5)	45	250	45	14	24	62	105	60	80	45	20	106	3 Kg
CTSR-36	10 T	5	M36 (x4)	54	320	54	19	30	81	140	80	111	71	30	148	7,6 Kg
CTSR-42	12,5 T	5	M42 (x4,5)	63	400	58	19	30	84	146	80	111	71	30	148	7,8 Kg
CTSR-48	20 T	4	M48 (x5)	68	600	69	19	30	100	178	110	135	90	42	180	17,5 Kg
CTSR-56	22 T	4	M56 (x5,5)	78	600	73	19	30	104	184	110	135	90	42	190	18 Kg
CTSRNC-5-16	650 LBS	5	UNC 5/16"-18	15	7 FL.	18	5/16"	5/8"	33	56	30	41	25	10	58	0,4 Kg
CTSRNC-3-8	1,200 LBS	5	UNC 3/8"-16	17	8 FL.	18	5/16"	5/8"	33	56	30	41	25	10	58	0,4 Kg
CTSRNC-1-2	2,200 LBS	5	UNC 1/2"-13	21	12 FL.	18	5/16"	5/8"	33	56	30	41	25	10	58	0,4 Kg
CTSRNC-5-8	3,800 LBS	5	UNC 5/8"-11	27	40 FL.	24	5/16"	20	45	75	45	56	37	14	79	1,1 Kg
CTSRNC-3-4	5,500 LBS	5	UNC 3/4"-10	30	80 FL.	24	5/16"	20	45	75	45	56	37	14	79	1,2 Kg
CTSRNC-7-8	6,600 LBS	5	UNC 7/8"-9	33	100 FL.	18	9/16"	24	62	84	60	80	45	20	106	2,7 Kg
CTSRNC-1	10,000 LBS	5	UNC 1"-8	36	125 FL.	41	9/16"	24	62	84	60	80	45	20	106	2,8 Kg
CTSRNC-1-1-4	14,000 LBS	5	UNC 1 1/4"-7	46	200 FL.	41	9/16"	24	84	146	80	111	71	30	106	7,1 Kg
CTSRNC-1-1-2	20,000 LBS	5	UNC 1 1/2"-6	61	300 FL.	54	3/4"	30	84	146	80	111	71	30	148	7,7 Kg
CTSRNC-2	50,000 LBS	4	UNC 2"-4 1/2	76	450 FL.	66	3/4"	30	104	184	110	135	90	42	190	17,7 Kg

* no estándar / non-standard

CMU = Carga Máxima de Utilización / WLL = Working Load Limit

T = Tonelada / Tone

Otras variantes del eje de fijación bajo solicitud / Other variants of the fixing axis available upon request