

E1230

PATENTE REGISTRADA
PATENTS FILED

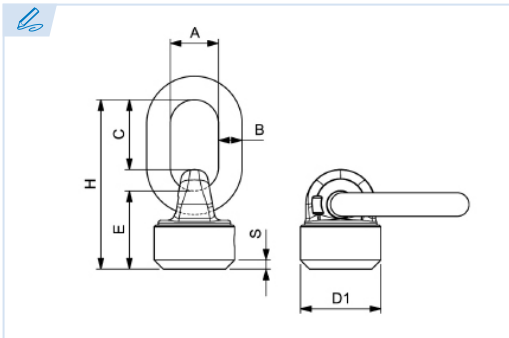

BREVETS DÉPOSÉS
PATENTE REGISTRADA



Cáncamo giratorio para soldar con anilla
Rotating eyebolt weld-on type with ring
Anneau de levage à émerillon à souder avec anneau
Olhal giratório de elevação soldável

Grado 100
Grade 100
Grade 100
Grau 100

Coefficiente de seguridad = 4
Safety factor = 4
Coefficient de sécurité = 4
Coeficiente de segurança = 4

Fabricación conforme a la norma europea EN 1677-1
Production according to the european standard EN 1677-1.
Production selon la norme européenne EN 1677-1.
Produção segundo a norma europeia: EN 1677-1.

Conforme a la directiva europea 2006/42/CE
In accordance with the new european directive 2006/42/CE.
Conforme à la directive européenne machines 2006/42/CE.
Conforme a norma europeia 2006/42/CE.

ES EN FR PT

CMU Carga máxima de utilización
Working load limit
Charge maximale d'utilisation
Carga máxima de trabalho

4:1 Coeficiente de seguridad 4:1
Safety factor 4:1
Coefficient de sécurité 4:1
Coeficiente de segurança 4:1

T Tonelada
Tone
Tonne
Tonelada

Ref.	CMU 4:1	A	B	C	E	H	D1	S x 45°	Kg.
E1230-2,5	2,5 T	34	16	58	61	131	52	5,5	1,05
E1230-4	4 T	40	18	72	67	152	58	7	1,44
E1230-6,7	6,7 T	45	22	65	73	158	75	8,5	2,7
E1230-10	10 T	50	23	92	86	201	85	10	3,95
E1230-17	17 T	70	32	120	105	255	110	12	8,5

