

E3101

PATENTE REGISTRADA
PATENTS FILED

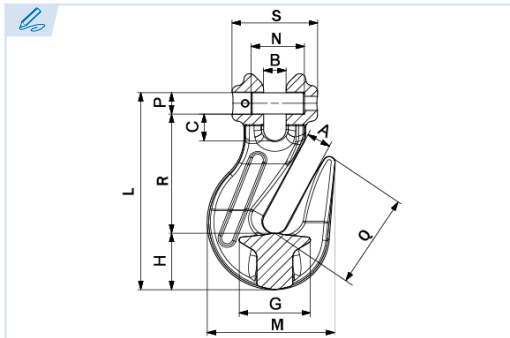

BREVETS DÉPOSÉS
PATENTE REGISTRADA



Gancho acortador cadena con horquilla
Clevis grab hook with/without latch
Crochet de raccourcissement à chape avec/sans linguet
Gancho encurtador de forqueta

Grado 100
Grade 100
Grade 100
Grau 100

Conforme a la directiva europea 2006/42/CE
In accordance with the new european directive 2006/42/CE.
Conforme à la directive européenne machines 2006/42/CE.
Conforme a norma europeia 2006/42/CE.

ES EN FR PT

CMU Carga máxima de utilización

Working load limit
Charge maximale d'utilisation
Carga máxima de trabalho

T Tonelada

Tone
Tonne
Tonelada

Ref. Import sin seguro	Ø Cadena		CMU	A	B	G	H	R	L	M	S	P	Kg.
	mm	inch											
E3101-6	6	1/4	1,4 T	8	7,5	25,5	18	44,5	77,5	46,5	32	7,5	0,22
E3101-8	8	5/16	2,5 T	11	9,5	33,5	22	53	93	54	36	10	0,34
E3101-10	10	3/8	4 T	13,5	12,5	42	31	73	127	72	46	113	0,82
E3101-13	13	1/2	6,7 T	15	15	53,5	45,5	92	164	96	59	16	1,75
E3101-16	16	5/8	10 T	19	18,5	74	48,8	103	188	115	70	19,5	2,88
E3101-20	20	3/4	16 T	25	24	87	55	123	223	145	85	24	4,84

