

## E3160

PATENTE REGISTRADA  
PATENTS FILED

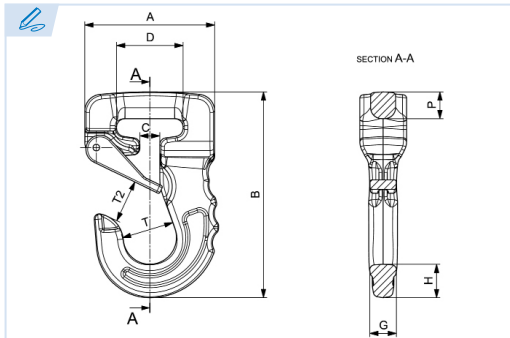

BREVETS DÉPOSÉS  
PATENTE REGISTRADA



**Gancho acortador cadena con horquilla**  
*Clevis grab hook with/without latch*  
 Crochet de raccourcissement à chape avec/sans linguet  
 Gancho encurtador de forqueta

**Grado 100**

Grade 100

Grade 100

Grau 100

Conforme a la directiva europea 2006/42/CE  
 In accordance with the new european directive 2006/42/CE.  
 Conforme à la directive européenne machines 2006/42/CE.  
 Conforme a norma europeia 2006/42/CE.

ES EN FR PT

**CMU Carga máxima de utilización**

Working load limit  
 Charge maximale d'utilisation  
 Carga máxima de trabalho

**T Tonelada**

Tone  
 Tonne  
 Tonelada

Color	Ref. EU	CMU	A	B	C	D	G	H	P	T	T2	Kg.
	E3160-1-Vi	1 T	78	123	12	41	17	20	16	31	26	0,7
	E3160-2-Ve	2 T	91	148	19	55	21	26	17	40	31	1,2
	E3160-3-Am	3 T	113	175	21	55	25	32	25	50	37	2,2
	E3160-4-Gr	4 T	133	223	40	70	36	40	36	59,5	43	4,5
	E3160-5-Ro	5 T	133	223	40	70	36	40	36	59,5	43	4,5
	E3160-6-Ma	6 T	133	223	40	70	36	40	36	59,5	43	4,5
	E3160-8-Az	8 T	188	302	50	105	40	60	42	80	65	12,75
	E3160-10-Na	10 T	188	302	50	105	40	60	42	80	65	12,75

