

E3171

PATENTE REGISTRADA
PATENTS FILED

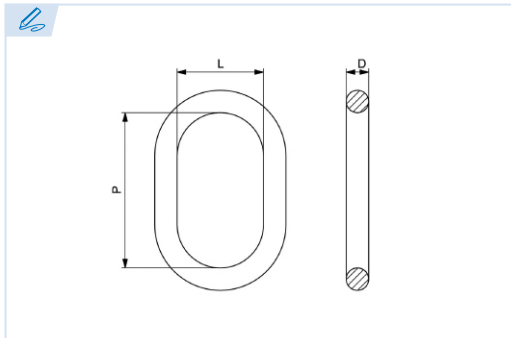

BREVETS DÉPOSÉS
PATENTE REGISTRADA



Anilla maestra oval
Oblong masterlink
Maille de tête ovale
Argolão

Grado 100
Grade 100
Grade 100
Grau 100

Conforme a la directiva europea 2006/42/CE
In accordance with the new european directive 2006/42/CE.
Conforme à la directive européenne machines 2006/42/CE.
Conforme a norma europeia 2006/42/CE.

ES EN FR PT

CMU Carga máxima de utilización

Working load limit
Charge maximale d'utilisation
Carga máxima de trabalho

T Tonelada

Tone
Tonne
Tonelada

Ref. Import	Ø Cadena		CMU 0°/Kg	CMU 0°45°/Kg	Dimensiones DIN 5688-36			Kg.
	⊥	∧			D	P	L	
E3171-6-7	7	6	1,9 T	2 T	13	110	60	0,34
E3171-7-8	8	7	2,5 T	2,65 T	16	110	60	0,53
E3171-8-10	10	8	4 T	3,55 T	18	135	75	0,8

