

E3230-1

PATENTE REGISTRADA
PATENTS FILED

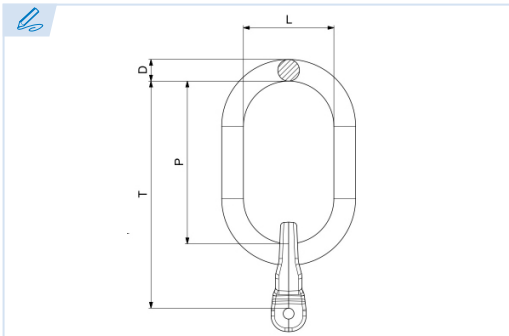

BREVETS DÉPOSÉS
PATENTE REGISTRADA



Anilla con juntura de horquilla
Master link with clevis attachment
Maille de tête avec attache à chape
Argolão com adaptador clevis

Grado 100

Grade 100

Grade 100

Grau 100

Conforme a la directiva europea 2006/42/CE
In accordance with the new european directive 2006/42/CE.
Conforme à la directive européenne machines 2006/42/CE.
Conforme a norma europeia 2006/42/CE.

ES EN FR PT

CMU Carga máxima de utilización

Working load limit
Charge maximale d'utilisation
Carga máxima de trabalho

T Tonelada

Tone
Tonne
Tonelada

Ref.	Ø Cadena	CMU	Dimensiones EN 1677-4				Kg.
			D	P	L	T	
E3230-1-6	6	1,12 T	13	110	60	140	0,58
E3230-1-8	8	2 T	16	110	60	151	0,88
E3230-1-10	10	3,15 T	18	135	75	185	1,35
E3230-1-13	13	5,3 T	22	160	90	223	2,4
E3230-1-16	16	8 T	26	180	100	257	4

