

E3230-2

PATENTE REGISTRADA
PATENTS FILED

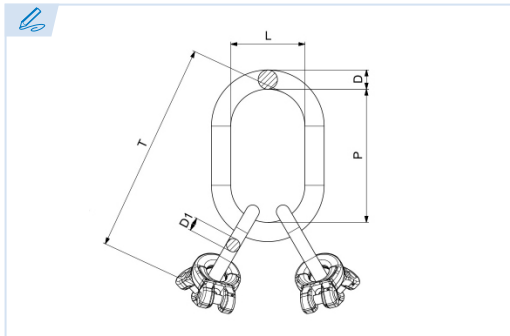

BREVETS DÉPOSÉS
PATENTE REGISTRADA



Anilla con juntura de horquilla
Master link with clevis attachment
Maille de tête avec attache à chape
Argolão com adaptador clevis

Grado 100

Grade 100

Grade 100

Grau 100

Conforme a la directiva europea 2006/42/CE

In accordance with the new european directive 2006/42/CE.

Conforme à la directive européenne machines 2006/42/CE.

Conforme a norma europeia 2006/42/CE.

ES EN FR PT

CMU Carga máxima de utilización

Working load limit

Charge maximale d'utilisation

Carga máxima de trabalho

T Tonelada

Tone

Tonne

Tonelada

Ref.	Ø Cadena	CMU		Dimensiones EN 1677-4				Kg.
		0° - 45°	45° - 60°	D	P	L	T	
E3200-2-6	6	2000	1400	13	60	110	195	0,95
E3200-2-7	7	2650	1900	16	60	110	230	1,8
E3200-2-8	8	3550	2500	18	75	135	255	2,2
E3200-2-10	10	5600	4000	22	90	160	320	4
E3200-2-13	13	9500	6700	26	100	180	382	7,7
E3200-2-16	16	14000	10000	32	110	200	430	13,5

