

E4151

PATENTE REGISTRADA | | BREVETS DÉPOSÉS
PATENTS FILED | PATENTE REGISTRADA

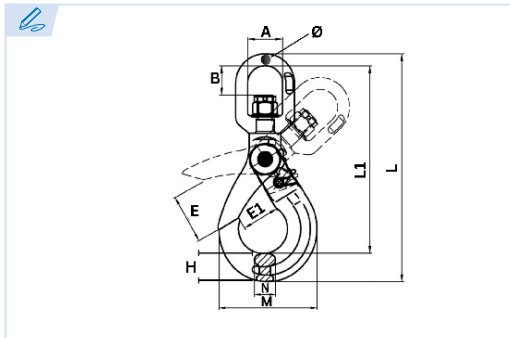

Gancho giratorio con autocierre
Swivel self locking hook
Crochet sécurisé à émerillon avec linguet automatique
Gancho de segurança giratório autoblocante

Grado 80
Grade 80
Grade 80
Grau 80

Conforme a la directiva europea 2006/42/CE
In accordance with the new european directive 2006/42/CE.
Conforme à la directive européenne machines 2006/42/CE.
Conforme a norma europeia 2006/42/CE.

CMU Carga máxima de utilización

Working load limit
Charge maximale d'utilisation
Carga máxima de trabalho

T Tonelada

Tone
Tonne
Tonelada

Ref. Import	Ø Cadena		CMU	A	B	E	E1	H	L	L1	M	N	Ø	Kg.
E4151-6	6	1/4"	1,12 T	32,5	25,5	32	28	20	184	152	73	15	12	0,7
E4151-8	7-8	9/32-5/16"	2 T	36	29,5	40	35	26	228	189	91	20	13	1,21
E4151-10	10	3/8"	3,15 T	42	39	48	45	30	268	223	108	26	15	1,98
E4151-13	13	1/2"	5,3 T	50	41	57	52,5	40	323	267	142	33	16	3,59
E4151-16	16	5/8"	8 T	61	58	65	63	50,5	411	339	168,5	38	21	7,27
E4151-20	20	3/4"	12,5 T	72	63	82	82	55	452	370	185	50	27	10,75
E4151-22	22	7/8"	15 T	97	98	80	76	67	564	466	202	52	31	17,5
E4151-26	26	12	21,5 T	123	115	109	96	75	661	544	239	60	42	23
E4151-32	32	1 1/4"	31,5 T	140	147	131	131	97	830	679	329	79,5	54	65

