

## E4171

PATENTE REGISTRADA  
PATENTS FILED

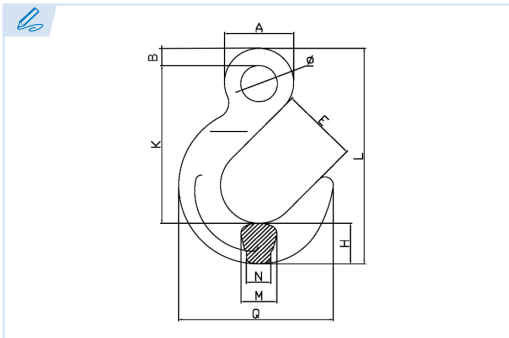

BREVETS DÉPOSÉS  
PATENTE REGISTRADA



### Gancho de fundición

Foundry hook  
Crochet de fonderie  
Gancho de fundição

### Grado 80

Grade 80  
Grade 80  
Grau 80

Conforme a la directiva europea 2006/42/CE  
In accordance with the new european directive 2006/42/CE.  
Conforme à la directive européenne machines 2006/42/CE.  
Conforme a norma europeia 2006/42/CE.

ES EN FR PT

### CMU Carga máxima de utilización

Working load limit  
Charge maximale d'utilisation  
Carga máxima de trabalho

### T Tonelada

Tone  
Tonne  
Tonelada

Ref. Import	Ø Cadena		CMU	A	D	G	H	O	R	G	H	O	R	Kg.
E4171-6	6	1/4"	1,12 T	40	11	63	31	121	163	25,5	18	121	18	1,05
E4171-8	7-8	9/32-5/16"	2 T	40	11	63	31	121	163	25,5	18	121	18	1,05
E4171-10	10	3/8"	3,15 T	51	16	76	38	147	201	32,5	23	146	22	2,03
E4171-13	13	1/2"	5,3 T	63,5	20	88	44,5	175	239,5	38	27	169	27	3,19
E4171-16	16	5/8"	8 T	76	22	102	52	206	280	46	32	198	32	5,39
E4171-20	20	3/4"	12,2 T	89	25	112,5	65	235,5	327,5	56	39	232	38	9,1
E4171-22	22	7/8"	15 T	102	29	127,5	69	263	361	57	40	256	45	11,6
E4171-26	26	1"	21,2 T	126	32	140	75	295	402	66	45	285	66,5	16,8
E4171-32	32	1 1/4"	31,5 T	151,5	35	151	97,5	328	460,5	80	58	324	81,5	27,2

