

**E4291**

PATENTE REGISTRADA  
PATENTS FILED

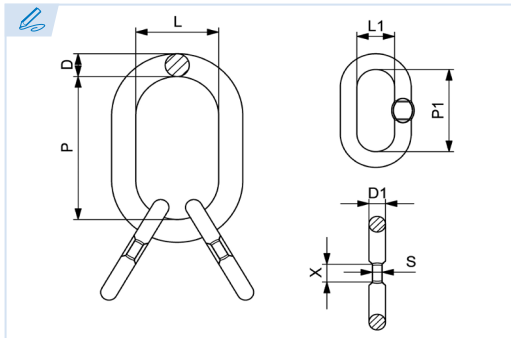

BREVETS DÉPOSÉS  
PATENTE REGISTRADA



**Anilla maestra oval ensamblada**

Sub-assembly  
Maillon de tête triple  
Argolão com subelos

**Grado 80**

Grade 80

Grade 80

Grau 80

Conforme a la directiva europea 2006/42/CE  
In accordance with the new european directive 2006/42/CE.  
Conforme à la directive européenne machines 2006/42/CE.  
Conforme a norma europeia 2006/42/CE.

**ES EN FR PT**

**CMU Carga máxima de utilización**

Working load limit  
Charge maximale d'utilisation  
Carga máxima de trabalho

**T Tonelada**

Tone  
Tonne  
Tonelada

Ref. Import sin aplastamiento	Ø Cadena	CMU		Dimensiones EN 1677-4						Kg.
		∧ 0°- 45°	∧ 45°- 60°	D	P	L	D1	P1	L1	
E4291-6	6	2,36 T	1,7 T	18	135	75	14	54	25	1,26
E4291-7	7	3,15 T	2,24 T	18	135	75	14	60	38	1,32
E4291-8	8	4,25 T	3 T	22	160	90	16	70	34	2,2
E4291-10	10	6,7 T	4,75 T	25	180	100	18	85	40	3,2
E4291-13	13	11,2 T	8 T	32	200	110	22	115	50	6,1
E4291-16	16	17 T	11,8 T	36	260	140	25	140	65	9,67
E4291-18	18	21,2 T	15 T	45	340	180	32	180	100	18,9
E4291-20	20	26,5 T	19 T	50	350	190	32	180	100	23,7
E4291-22	22	31,5 T	22,4 T	50	350	190	36	180	100	25,2
E4291-26	26	45 T	31,5 T	57	406	203	40	180	100	36,3
E4291-32	32	67 T	47 T	72	460	250	50	200	110	66,4

