

E4340-1

PATENTE REGISTRADA
PATENTS FILED

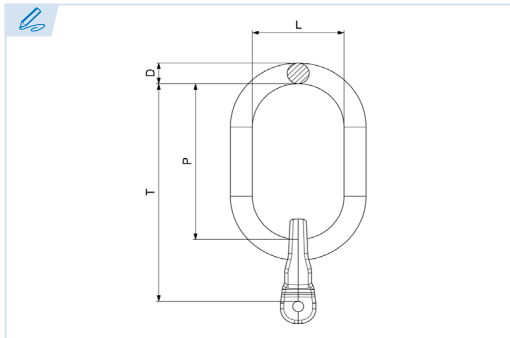

BREVETS DÉPOSÉS
PATENTE REGISTRADA



Anillas con juntura de horquilla
Master links with clevis attachments
Maillon de tête avec attache à chape
Olhal com adaptador de garfo

Grado 80

Grade 80

Grade 80

Grau 80

Capacidad según EN 818-4/DIN5688-3

W.L.L. according to EN 818-4/DIN5688-3

C.M.U. selon standard EN 818-4/DIN5688-3

Capacidade de acordo com EN 818-4/DIN5688-3

Conforme a la directiva europea 2006/42/CE

In accordance with the new european directive 2006/42/CE.

Conforme à la directive européenne machines 2006/42/CE.

Conforme a norma europeia 2006/42/CE.

ES EN FR PT

CMU Carga máxima de utilización

Working load limit

Charge maximale d'utilisation

Carga máxima de trabalho

T Tonelada

Tone

Tonne

Tonelada

Ref.	Ø Cadena	CMU	Ø D	Dimensiones EN 1677-4			Kg.
				P	L	T	
E4340-1-6	6	1,12 T	13	110	60	140	0,58
E4340-1-8	8	2 T	16	110	60	151	0,88
E4340-1-10	10	3,15 T	18	135	75	185	1,35
E4340-1-13	13	5,3 T	22	160	90	223	2,4
E4340-1-16	16	8 T	26	180	100	257	4

