

E4340-2

PATENTE REGISTRADA
PATENTS FILED

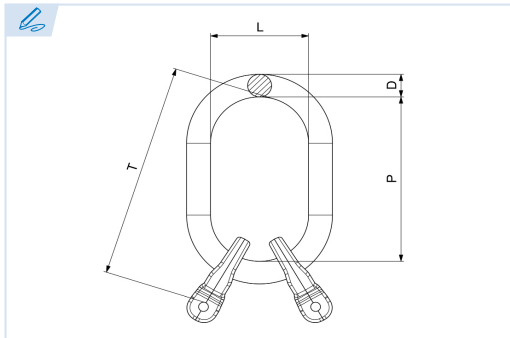

BREVETS DÉPOSÉS
PATENTE REGISTRADA



Anillas con juntura de horquilla
Master links with clevis attachments
Maillon de tête avec attache à chape
Olhal com adaptador de garfo

Grado 80

Grade 80

Grade 80

Grau 80

Capacidad según EN 818-4/DIN5688-3

W.L.L. according to EN 818-4/DIN5688-3

C.M.U. selon standard EN 818-4/DIN5688-3

Capacidade de acordo com EN 818-4/DIN5688-3

Conforme a la directiva europea 2006/42/CE

In accordance with the new european directive 2006/42/CE.

Conforme à la directive européenne machines 2006/42/CE.

Conforme a norma europeia 2006/42/CE.

ES EN FR PT

CMU Carga máxima de utilización

Working load limit

Charge maximale d'utilisation

Carga máxima de trabalho

T Tonelada

Tone

Tonne

Tonelada

Ref.	Ø Cadena Δ	Dimensiones EN 1677-4				Kg.	⊥ CMU 0° - 45°	^ CMU 45° - 60°
		Ø D	P	L	T			
E4340-2-6	6	13	110	60	140	0,7	1600 T	1120 T
E4340-2-8	8	18	135	75	176	1,4	2800 T	2000 T
E4340-2-10	10	22	160	90	210	2,45	4250 T	3150 T
E4340-2-13	13	26	180	100	243	4,2	7500 T	5300 T
E4340-2-16	16	32	200	110	277	7,05	11200 T	8000 T

