

## E5020

PATENTE REGISTRADA  
PATENTS FILED



BREVETS DÉPOSÉS  
PATENTE REGISTRADA

• INOX

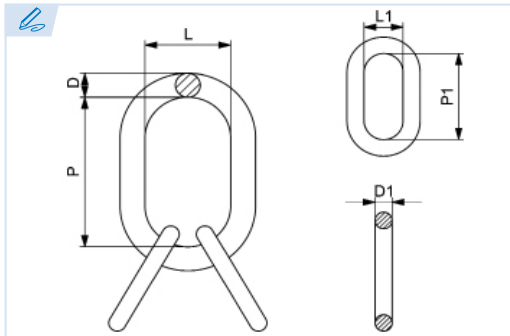

**Anilla ensamblada de acero inoxidable**  
Stainless steel sub-assembly  
Maillon de tête triple in acier inox  
Argolão com subelos inox

**Grado 60**

Grade 60

Grade 60

Grau 60

Conforme a la directiva europea 2006/42/CE

In accordance with the new european directive 2006/42/CE.

Conforme à la directive européenne machines 2006/42/CE.

Conforme a norma europeia 2006/42/CE.

ES EN FR PT

**CMU Carga máxima de utilización**

Working load limit

Charge maximale d'utilisation

Carga máxima de trabalho

**T Tonelada**

Tone

Tonne

Tonelada

Ref.	Ø Cadena	CMU	Dimensiones EN 1677-4						Kg.
			D	P	L	D1	P1	L1	
E5020-6	6	1,89 T	13	110	60	10	44	20	0,52
E5020-7	7	2,6 T	16	110	60	13	54	25	0,97
E5020-8	8	3,35 T	18	135	75	16	70	34	1,6
E5020-10	10	5,25 T	22	160	90	18	85	40	2,76
E5020-13	13	8,9 T	26	180	100	22	115	50	4,45
E5020-16	16	13,2 T	32	200	110	26	140	65	7,55

