

E5090

PATENTE REGISTRADA
PATENTS FILED



BREVETS DÉPOSÉS
PATENTE REGISTRADA

INOX

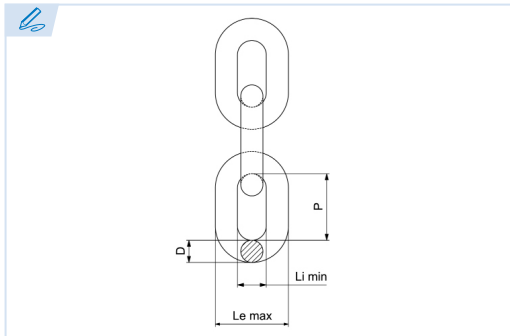

Cadena de acero inoxidable
Stainless steel chain
Chaîne in acier inox
Corrente inox

Grado 60
Grade 60
Grade 60
Grau 60

Conforme a la directiva europea 2006/42/CE
In accordance with the new european directive 2006/42/CE.
Conforme à la directive européenne machines 2006/42/CE.
Conforme a norma europeia 2006/42/CE.

ES EN FR PT

CMU Carga máxima de utilización

Working load limit
Charge maximale d'utilisation
Carga máxima de trabalho

T Tonelada

Tone
Tonne
Tonelada

Ref.	Ø Cadena		CMU	P	Tolerancia	Li min	Le max	B.F.	Peso
E5090-6-1-50	6	1 / 4"	0,9 T	18	± 0,5	7,8	22,2	35,3	0,8
E5090-7-1-50	7	9 / 32"	1,25 T	21	± 0,6	9,1	25,9	49,1	1,1
E5090-8-1-50	8	5 / 16"	1,6 T	24	± 0,7	10,4	29,6	62,8	1,4
E5090-10-1-30	10	3 / 8"	2,5 T	30	± 0,9	13	37	98,1	2,2
E5090-13-1-30	13	1 / 2"	4,25 T	39	± 1,2	16,9	48,1	166,8	3,8
E5090-16-1-30	16	5 / 8"	6,3 T	48	± 1,4	20,8	59,2	247,3	5,7

