

E6060

PATENTE REGISTRADA
PATENTS FILED

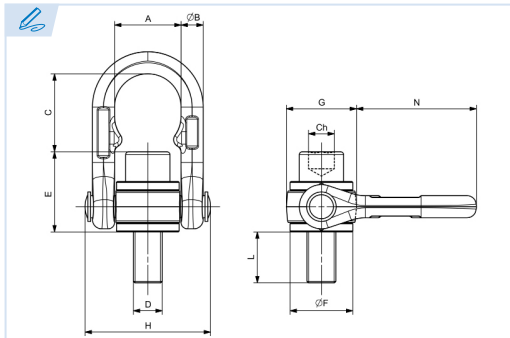

BREVETS DÉPOSÉS
PATENTE REGISTRADA



Cáncamo rotatorio con articulación
Heavy lift swivel hoist ring
Anneau de levage avec articulation
Olhal de elevação articulado

Acero 20CrNiMo+Al
Steel 20CrNiMo+Al
Acier 20CrNiMo+Al
Aço 20CrNiMo+Al

Conforme a la directiva europea 2006/42/CE
In accordance with the new european directive 2006/42/CE.
Conforme à la directive européenne machines 2006/42/CE.
Conforme a norma europeia 2006/42/CE.

ES EN FR PT

CMU Carga máxima de utilización
Working load limit
Charge maximale d'utilisation
Carga máxima de trabalho

5:1 Coeficiente de seguridad 5:1
Safety factor 5:1
Coefficient de sécurité 5:1
Coeficiente de segurança 5:1

T Tonelada
Tone
Tonne
Tonelada

Ref.	CMU 5:1	M	A	B	C	D	E	F	G	H	L	N	Ch	Kg.
E6060-8	0,4 T	M8	36	12	50	M8	35	34	38	68	18	53	6	0,46
E6060-10	0,7 T	M10	36	12	48	M10	37	34	38	68	18	53	8	0,47
E6060-12	1 T	M12	36	12	46	M12	39	34	38	68	23	53	10	0,48
E6060-14	1,3 T	M14	36	12	44	M14	41	34	38	68	23	53	12	0,5
E6060-16	1,6 T	M16	36	12	42	M16	43	34	38	68	28	53	14	0,53

