

E6130

PATENTE REGISTRADA
PATENTS FILED

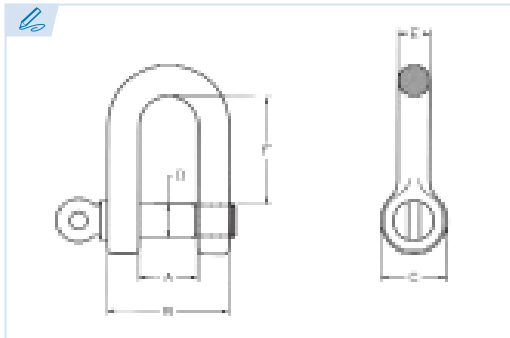

BREVETS DÉPOSÉS
PATENTE REGISTRADA



Grillete recto galvanizado
Galvanized forged dee shackle
Manille droite zingué
Manilha direita galvanizada

Acero Fe 430 B

Steel Fe 430 B

Acier Fe 430 B

Aço Fe 430 B

Conforme a la directiva europea 2006/42/CE

In accordance with the new european directive 2006/42/CE.

Conforme à la directive européenne machines 2006/42/CE.

Conforme a norma europeia 2006/42/CE.

ES EN FR PT

CMU Carga máxima de utilización

Working load limit

Charge maximale d'utilisation

Carga máxima de trabalho

T Tonelada

Tone

Tonne

Tonelada

Ref.	CMU	M	A	B	C	D	E	F	Kg.
E6130-5	0,07 T	5	8	18	12	5	5	23	0,02
E6130-6	0,1 T	6	11	23	14	6	6	29	0,04
E6130-8	0,25 T	8	16	32	18	8	8	37	0,08
E6130-10	0,40 T	10	19	38	21	10	10	41	0,11
E6130-11	0,47 T	11	23	45	26	11	11	48	0,2
E6130-12	0,63 T	12	26	50	28	12	12	54	0,25
E6130-14	0,75 T	14	28	56	30	14	14	57	0,34
E6130-16	1 T	16	30	64	35	16	16	63	0,51
E6130-18	1,3 T	18	28	64	37	18	18	62	0,75
E6130-20	1,6 T	20	35	68	39	20	18,5	65	0,94
E6130-22	2 T	22	41	83	44	22	21	75	1,3
E6130-25	2,5 T	25	36	80	50	25	22	81	1,6
E6130-28	3,15 T	28	40	88	56	28	24	90	2
E6130-32	4 T	32	45	99	64	32	27	99	2,9
E6130-36	5 T	36	50	110	74	36	30	109	4,3
E6130-40	6,3 T	40	55	123	80	40	34	120	6
E6130-42	8 T	42	60	136	85	42	38	131	7,4
E6130-45	10 T	45	65	149	90	45	42	135	10
E6130-50	12,5 T	50	70	165	103	48	47	155	13,7
E6130-56	16 T	56	80	184	114	56	52	170	16,6