

E6140

PATENTE REGISTRADA
PATENTS FILED

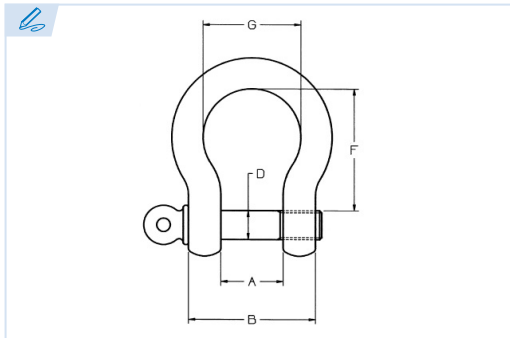

BREVETS DÉPOSÉS
PATENTE REGISTRADA



Grillete lira galvanizado
Galvanized forged bow shackle
Manille lyre zingué
Manilha cavilha galvanizada

Acero Fe 430 B

Steel Fe 430 B

Acier Fe 430 B

Aço Fe 430 B

Conforme a la directiva europea 2006/42/CE

In accordance with the new european directive 2006/42/CE.

Conforme à la directive européenne machines 2006/42/CE.

Conforme a norma europeia 2006/42/CE.

ES EN FR PT

CMU Carga máxima de utilización

Working load limit

Charge maximale d'utilisation

Carga máxima de trabalho

T Tonelada

Tone

Tonne

Tonelada

Ref.	CMU	M	A	B	C	D	E	F	G	Kg.
E6140-5	0,08 T	5	9	20	10	5	5	20	18	0,02
E6140-6	0,1 T	6	12	24	12	6	6	26	19	0,03
E6140-8	0,2 T	8	15	33	17	8	8	31	24	0,08
E6140-10	0,3 T	10	16	37	20	10	10	38	30	0,1
E6140-11	0,4 T	11	21	46	22	11	11	44	35	0,18
E6140-12	0,5 T	12	23	49	24	12	12	53	39	0,28
E6140-14	0,6 T	14	30	61	30	14	15	59	47	0,39
E6140-16	0,8 T	16	30	64	31	16	18	64	48	0,48
E6140-18	1,1 T	18	35	75	41	18	19,5	72	59	0,9
E6140-20	1,1 T	20	35	75	41	20	19,5	72	59	0,96
E6140-22	1,5 T	22	46	89	49	22	22	85	61	1,37
E6140-25	2 T	24	50	100	57	25	26	102	76	2,28
E6140-28	2,6 T	28	53	110	61	28	28	111	81	2,86
E6140-32	3,2 T	32	56	119	62	32	31	117	82	4,1
E6140-39	4,5 T	39	75	150	80	38	41	155	115	7,3

