

E6150

PATENTE REGISTRADA
PATENTS FILED

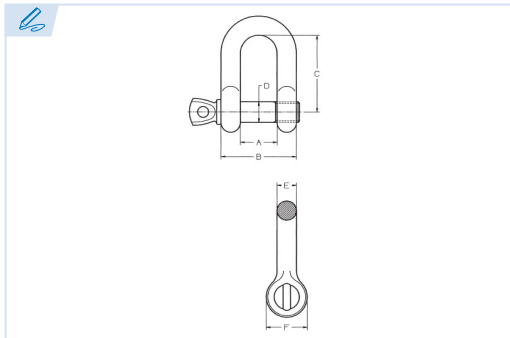

BREVETS DÉPOSÉS
PATENTE REGISTRADA



Grillete recto
Dee shackle
Manille droite
Manilha direita

Acero Fe 430 B
Steel Fe 430 B
Acier Fe 430 B
Aço Fe 430 B

Conforme a la directiva europea 2006/42/CE
In accordance with the new european directive 2006/42/CE.
Conforme à la directive européenne machines 2006/42/CE.
Conforme a norma europeia 2006/42/CE.

ES EN FR PT

CMU Carga máxima de utilización

Working load limit
Charge maximale d'utilisation
Carga máxima de trabalho

T Tonelada

Tone
Tonne
Tonelada

Ref.	CMU	M	A	B	C	D	E	F	Kg.
E6150-5	0,07 T	5	10	20	21	5	5	11	0,014
E6150-6	0,1 T	6	13	25	28	6	6	14	0,03
E6150-8	0,25 T	8	16	32	36	8	8	18	0,047
E6150-10	0,4 T	10	19	39	43	10	10	20	0,09
E6150-11	0,47 T	11	22	44	50	11	11	24	0,12
E6150-12	0,63 T	12	25	49	57	12	12	28	0,17
E6150-14	0,75 T	14	28	56	64	14	14	30	0,31
E6150-16	1 T	16	32	64	72	16	16	33	0,38
E6150-18	1,3 T	18	37	70	74	18	18	33,5	0,73
E6150-20	1,6 T	20	38	78	86	20	20	40	0,73
E6150-22	2 T	22	44	88	91	22	22	50	1,32
E6150-24	2,5 T	24	48,5	97	99	24	24	47,5	2,07
E6150-28	3,15 T	28	57	113	129	28	28	68	2,88
E6150-32	4 T	32	64	128	143	32	32	73	3,6
E6150-36	5 T	36	72	144	155	36	36	80	5,8
E6150-38	6 T	38	76	152	171	38	38	85	6,1
E6150-42	8 T	42	84	168	185	42	42	90	7,8
E6150-45	10 T	45	90	180	202	45	45	98	11
E6150-50	12,5 T	50	102	202	225	50	50	108	14

