

## E6160

PATENTE REGISTRADA  
PATENTS FILED

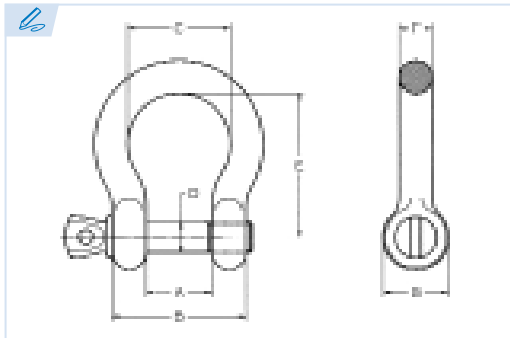

BREVETS DÉPOSÉS  
PATENTE REGISTRADA



**Grillete lira**  
Bow shackle  
Manille lyre  
Manilha cavilha

**Acero Fe 430 B**  
Steel Fe 430 B  
Acier Fe 430 B  
Aço Fe 430 B

Conforme a la directiva europea 2006/42/CE  
In accordance with the new european directive 2006/42/CE.  
Conforme à la directive européenne machines 2006/42/CE.  
Conforme a norma europeia 2006/42/CE.

ES EN FR PT

**CMU Carga máxima de utilización**

Working load limit  
Charge maximale d'utilisation  
Carga máxima de trabalho

**T Tonelada**

Tone  
Tonne  
Tonelada

Ref.	CMU	M	A	B	C	D	E	F	G	Kg.
E6160-5	0,08 T	5	10	20	16	5	21	5	11	0,02
E6160-6	0,1 T	6	13	25	20	6	28	6	14	0,03
E6160-8	0,2 T	8	16	32	24	8	36	8	18	0,08
E6160-10	0,3 T	10	19	39	32	10	43	10	20	0,13
E6160-11	0,4 T	11	22	44	35	11	50	11	24	0,15
E6160-12	0,5 T	12	25	49	38	12	57	12	28	0,23
E6160-14	0,6 T	14	28	56	44	14	64	14	30	0,36
E6160-16	0,8 T	16	32	64	50	16	72	16	32	0,37
E6160-18	1,1 T	18	38	74	56	18	86	18	35	0,73
E6160-20	1,1 T	20	38	78	66	20	86	20	40	1
E6160-22	1,5 T	22	44	88	74	22	91	22	50	1,43
E6160-24	2 T	24	48,5	95	68	24	108	24	47	2,04
E6160-28	2,6 T	28	57	113	94	28	129	28	68	2,88
E6160-32	3,2 T	32	64	128	104	32	143	32	73	4,1
E6160-36	4,2 T	36	72	144	115	36	155	36	80	5,3
E6160-38	4,5 T	38	76	152	136	38	171	38	85	7,4
E6160-42	6 T	42	84	168	142	42	185	42	90	8
E6160-45	7 T	45	90	180	150	45	202	45	98	12
E6160-50	8 T	50	102	202	156	50	225	50	108	15

