

E6430

PATENTE REGISTRADA
PATENTS FILED

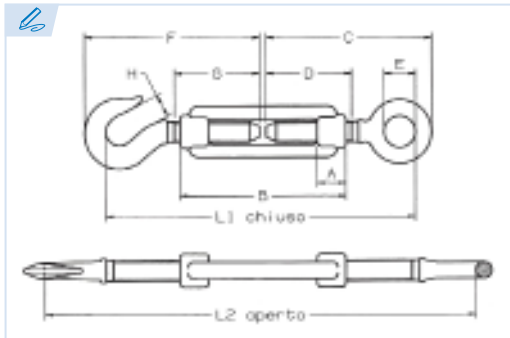

BREVETS DÉPOSÉS
PATENTE REGISTRADA



Tensor aro-gancho DIN 1480
Turnbuckle eye and hook DIN 1480
Tendeur anneau et crochet DIN 1480
Esticador olhal - gancho DIN 1480

Acero Fe 430 B

Steel Fe 430 B

Acier Fe 430 B

Aço Fe 430 B

Conforme a la directiva europea 2006/42/CE
In accordance with the new european directive 2006/42/CE.
Conforme à la directive européenne machines 2006/42/CE.
Conforme a norma europeia 2006/42/CE.

ES EN FR PT

CMU Carga máxima de utilización

Working load limit
Charge maximale d'utilisation
Carga máxima de trabalho

T Tonelada

Tone
Tonne
Tonelada

| Ref. Galvanizado. | Ref. Galvanizado en caliente | CMU | M | A | B | C | D | E | F | G | H | L1 | L2 | Kg. |
|-------------------|------------------------------|---------|-----|----|-----|-----|-----|----|-----|-----|------|-----|-----|------|
| E6430-6 | | 0,075 T | M6 | 12 | 110 | 74 | 50 | 10 | 76 | 50 | 8 | 140 | 226 | 0,09 |
| E6430-7 | | 0,165 T | M8 | 15 | 110 | 80 | 52 | 11 | 89 | 52 | 10 | 155 | 235 | 0,14 |
| E6430-8 | | 0,235 T | M10 | 18 | 125 | 97 | 60 | 14 | 103 | 62 | 13 | 185 | 273 | 0,28 |
| E6430-9 | | 0,32 T | M12 | 21 | 125 | 106 | 67 | 17 | 121 | 65 | 17 | 208 | 290 | 0,41 |
| E6430-10 | | 0,42 T | M14 | 24 | 140 | 126 | 83 | 18 | 144 | 82 | 14 | 248 | 344 | 0,57 |
| E6430-11 | E6440-16 | 0,53 T | M16 | 27 | 170 | 160 | 97 | 23 | 168 | 100 | 16,5 | 303 | 419 | 0,96 |
| E6430-12 | E6440-20 | 0,73 T | M20 | 34 | 200 | 190 | 116 | 25 | 185 | 110 | 17 | 341 | 473 | 1,54 |
| E6430-13 | E6440-24 | 1,12 T | M22 | 36 | 220 | 200 | 120 | 30 | 216 | 125 | 22 | 379 | 527 | 2,13 |
| E6430-14 | E6440-30 | 1,55 T | M24 | 39 | 255 | 210 | 125 | 34 | 225 | 125 | 23 | 391 | 568 | 2,84 |
| E6430-15 | | 1,87 T | M27 | 45 | 255 | 236 | 150 | 34 | 250 | 146 | 29 | 437 | 602 | 3,89 |
| E6430-16 | | 2,24 T | M30 | 45 | 255 | 242 | 150 | 39 | 250 | 140 | 30 | 439 | 604 | 4,15 |
| E6430-17 | | 2,85 T | M33 | 55 | 295 | 242 | 150 | 39 | 250 | 140 | 30 | 441 | 626 | 5,88 |
| E6430-18 | | 3,53 T | M36 | 55 | 295 | 276 | 165 | 49 | 288 | 170 | 30 | 497 | 682 | 7,53 |
| E6430-19 | | 4,15 T | M39 | 63 | 330 | 276 | 165 | 49 | 288 | 170 | 30 | 505 | 709 | 9,38 |