

E6540

PATENTE REGISTRADA
PATENTS FILED

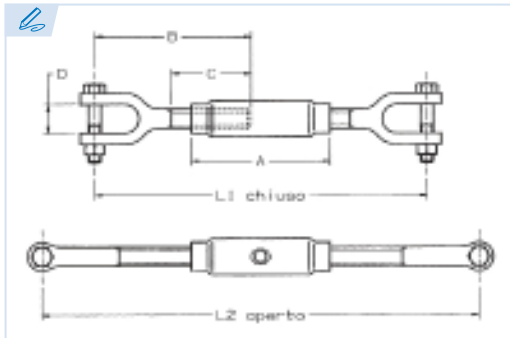

BREVETS DÉPOSÉS
PATENTE REGISTRADA



Tensor horquilla-horquilla tubular DIN 1478
Turnbuckle fork and fork DIN 1478
Tendeur à deux chapes DIN 1478
Esticador DIN 1478 forqueta - forqueta

Acero Fe 430 B

Steel Fe 430 B

Acier Fe 430 B

Aço Fe 430 B

Conforme a la directiva europea 2006/42/CE

In accordance with the new european directive 2006/42/CE.

Conforme à la directive européenne machines 2006/42/CE.

Conforme a norma europeia 2006/42/CE.

ES EN FR PT

CMU Carga máxima de utilización

Working load limit

Charge maximale d'utilisation

Carga máxima de trabalho

T Tonelada

Tone

Tonne

Tonelada

Ref.	CMU	M	A	B	C	D	L1	L2	Bulón	Kg.
E6540-6	20,3 T	M6	110	87	55	7	180	269	M 5X25	0,15
E6540-8	0,3 T	M8	110	95	55	9	198	280	M 6X31	0,26
E6540-10	0,47 T	M10	125	112	68	10	231	324	M 8X36	0,45
E6540-12	0,69 T	M12	125	121	68	13	252	337	M 10X45	0,66
E6540-16	1,29 T	M16	170	150	88	18	311	430	M 12X58	1,51
E6540-20	2,13 T	M20	200	182	105	20	374	516	M 16X71	2,93
E6540-24	3,06 T	M24	255	226	130	30	464	649	M 22X97	5
E6540-30	4,86 T	M30	255	252	140	36	504	711	M 24x85	9,97
E6540-36	6,5 T	M36	295	300	170	45	600	835	M 30x115	14,8